

SIDE VIEW

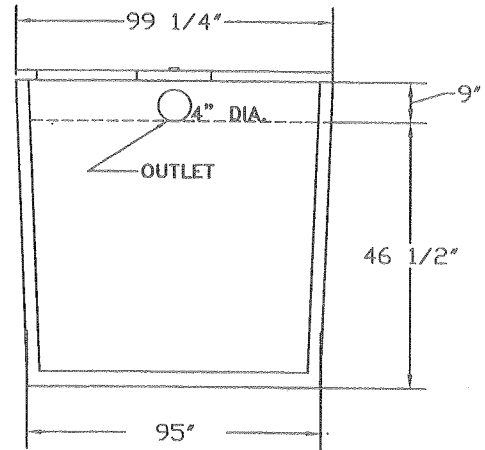

END VIEW

**TANK: CATEGORY 4.** 4" 2800 GALLON 1 COMPARTMENT TANK REINFORCED WITH FIBER AND #3 STEEL 12" O/C. BOTH WAYS. 4" WALLS AND 4" BOTTOM. INLET AND OUTLET RESILIENT CONNECTORS PER ASTM-923-98. CONNECTORS MUST BE USED WITH APPROVED CLAMP. CONNECTOR WILL ACCEPT 4" PVC PIPE.

**LIDS:** 5" LID WITH 1-22" ROUND MANHOLE COVER AT EACH END OF TANK  
 8" LID WITH 1-22" ROUND MANHOLE COVER AT EACH END OF TANK  
 BOTH LIDS ARE REINFORCED WITH GRADE 60 REBAR.

**TANK & LIDS:** 4000 PSI CONCRETE AT 28 DAYS

IMPRINTED ON INLET END OF TANK:  
**LEGEND: FSI 2800 STATE APPROVAL NUMBER: 01-011-52S-C4**

**WEIGHTS:** TANK ONLY 15,285  
 TANK & 5" LID 22,675  
 TANK & 8" LID 27,110

THIS SEWAGE TREATMENT RECEPTACLE HAS BEEN DESIGNED, CONSTRUCTED AND STRUCTURALLY TESTED IN ACCORDANCE WITH CHAPTER 64E-6.013, FLORIDA ADMINISTRATIVE CODE, (FAC) DATED MARCH 22, 2000

DRAWING NOT TO SCALE

**FLORIDA SEPTIC, INC.**  
 P.O. BOX 545  
 HAWTHORNE, FLORIDA 32640  
 (800) 940-8265

**MODEL:**  
 4" 2800 GAL. TANK

**REVISED:**  
 12/12/03

**APPROVAL DATE:**  
 08/14/01